

SEIKO





































QUARTZ

Cal. 7903A

PARTS LIST

Cal. 7903A



						
122 791	131 791	221 791	225 791	231 791	241 791	261 710
						
271 711	282 589	354 791	383 791	384 710	385 710	387 710
						
388 791	390 710	391 791	701 791	706 791	☆801 584	803 710
						
808 791	810 791	817 710	867 791	☆870 810	☆884 791	963 710
						
986 710	4001 791	4002 791	4146 791	4216 791	4239 791	4242 791
						
4408 792	☆U.C.C. 384					

						
022 282	022 424	022 468	022 764	027 810	027 811	027 817

3/1

Cal. 7903A

Characteristics

Casing diameter: ϕ 18.0 mm
 Maximum height: 4.0 mm without battery
 Jewels: 7 j
 Frequency of quartz crystal oscillator: 32,768 Hz (Hz = Hertz Cycle per second)
 Driving system: Step motor system (2 poles)
 Regulation system: Trimmer condenser
 Second-setting device
 Calendar (Day & Date)
 Instant setting device for day & date calendar
 Bilingual change-over system for day of the week
 Battery life indicator: Second hand moves in two-second interval.

PART NO.	PART NAME	PART NO.	PART NAME
122 791	Center wheel bridge	027 810	Pin for plus terminal of battery connection
131 791	Third wheel bridge	027 811	Date jumper pin
221 791	Center wheel & pinion	027 817	Minute wheel pin
225 791	Cannon pinion	011 406	Upper hole jewel for fourth wheel
231 791	Third wheel & pinion	011 503	Upper hole jewel for fifth wheel
241 791	Fourth wheel & pinion	011 503	Lower hole jewel for fifth wheel
261 710	Minute wheel	011 503	Upper hole jewel for step rotor
271 711	Hour wheel	011 541	Lower hole jewel for step rotor
282 589	Clutch wheel	011 541	Upper hole jewel for sixth wheel
354 791	Winding stem	011 541	Lower hole jewel for sixth wheel
383 791	Setting lever	☆U.C.C.384	Silver oxide battery
384 710	Yoke (Clutch lever)	☆Maxell SR41SW	Silver peroxide battery
385 710	Yoke spring (Clutch lever spring)	☆SEIKO SB-D1	
387 710	Setting lever spring		
388 791	Yoke spring holder		
390 710	Setting lever axle		
391 791	Second setting lever		
701 791	Fifth wheel & pinion		
706 791	Sixth wheel & pinion		
☆801 584	Date dial		
803 710	Setting wheel lever complete		
808 791	Date dial guard		
810 791	Date jumper		
817 710	Intermediate date wheel		
867 791	Day & date driving wheel		
☆870 810	Day star with dial disk		
☆884 790	Holding ring for dial		
☆884 791			
☆884 792			
963 710	Snap for day star with dial disk		
986 710	Day-date corrector wheel rocket		
4001 791	Circuit block		
4002 791	Coil block		
4146 791	Step rotor		
4216 791	Insulator for battery		
4239 791	Rotor stator		
4242 791	Plus terminal of battery connection		
4408 792	Insulating spacer for circuit block		
022 282	Setting lever spring screw		
022 282	Date dial guard screw		
022 424	Center wheel bridge screw		
022 424	Third wheel bridge screw		
022 424	Circuit block screw		
022 424	Coil block screw		
022 424	Second setting lever screw		
022 468	Yoke spring screw		
022 764	Dial screw		

☆ Please see remarks on the reverse page.
 Part numbers in light letters are not shown in photos.

Cal. 7903A

Remarks:

Date dial

☆801 584(Black figures on white background).....Used for both the crown and the calendar frame are located at 3 o'clock position.

If any other type of date dial is required, specify ① Cal. No. ② The crown position ③ The calendar frame position ④ Jewels and ⑤ Dial No.

Day star with dial disk

☆870 810(English ↔ Spanish, black figures on white background)

Used for both the crown and the calendar frame are located at 3 o'clock position.

If any other type of day star with dial disk is required, specify the number printed on the disk.

Holding ring for dial

☆884 790.....Used for the round dial whose diameter is 18 mm.

☆884 791.....Used for the round dial

☆884 792.....Used for the square dial.

The type of holding ring for dial is determined based on the design of cases and dials.

If the shape of the holding ring for dial is different from the above, or if the Part No. of the holding ring for dial is unknown, check the case number and refer to "**SEIKO Quartz Casing Parts List**" to choose a corresponding holding ring for dial.

Battery.....The applied battery for this calibre might be added the substitutive in the future. In that case, please refer to separate "BATTERIES FOR SEIKO QUARTZ WATCHES".

TECHNICAL GUIDE

SEIKO
QUARTZ

CAL. 7903A

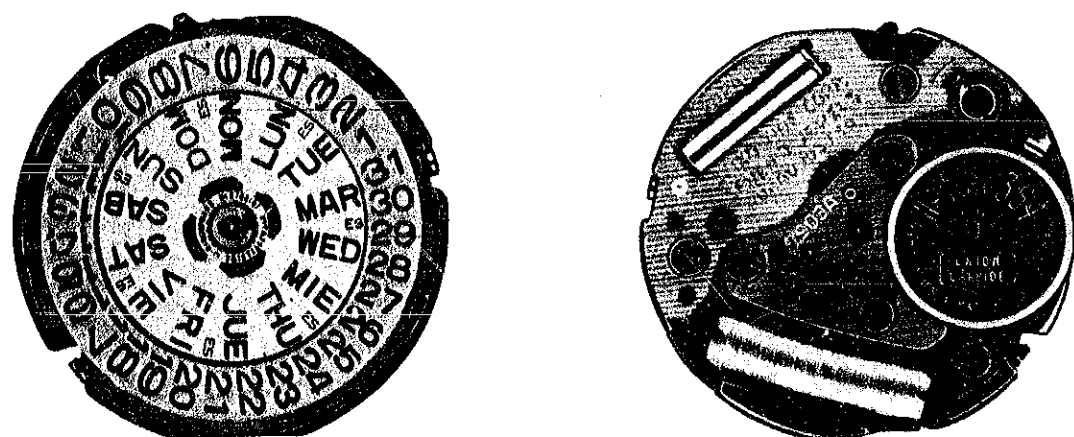

CONTENTS

I. SPECIFICATIONS	1
II. DISASSEMBLING, REASSEMBLING AND LUBRICATING	2
1. Disassembling, reassembling and lubricating of the calendar mechanism	3
2. Disassembling, reassembling and lubricating of the circuit block, coil block and gear train mechanism	4
3. Disassembling, reassembling and lubricating of the setting mechanism	5
III. CHECKING AND ADJUSTMENT	7
1. Guide table for checking and adjustment	7
2. Procedures for checking and adjustment	8
A: Check output signal	8
B: Check battery voltage	8
* How to check battery electrolyte leakage and repair	8
C: Check battery conductivity	10
D: Check circuit block conductivity	10
E: Check circuit block output terminal conductivity	10
F: Check coil block	12
G: Check output signal	12
H: Check second setting condition and reset condition	12
I : Check accuracy	14
J : Check current consumption	16

I. SPECIFICATIONS

Item	Cal. No.	7903A
Time indication		3-hand time indication (hour, minute & second)
Additional mechanism		Calendar (day & date) Bilingual changeover system for the day of the week Second setting device (stops at every second) Battery life indicator Electronic circuit reset switch
Crystal oscillator		32,768Hz (Hz = Hertz . . . Cycle per second)
Loss/gain		Loss/gain at normal temperature Monthly rate: less than 15 seconds (Annual rate: less than 3 minutes)
Casing diameter		φ18.0mm
Height		4.0mm without battery
Operational temperature range		-10°C ~ +60°C (14°F ~ 140°F)
Driving system		Step motor system (2 poles)
Regulation system		Trimmer condenser
Battery power		Silver oxide battery Maxell SR41SW, U.C.C. 384 Silver peroxide battery SEIKO SB-D1 Battery life is approximately 2 years. Voltage: 1.55V
Jewels		7 jewels

- SEIKO QUARTZ Cal. 7903A is a high accuracy quartz crystal oscillator watch having a second hand and a calendar. It has various functions but is thin and compact to be fit for everyday use by ladies.

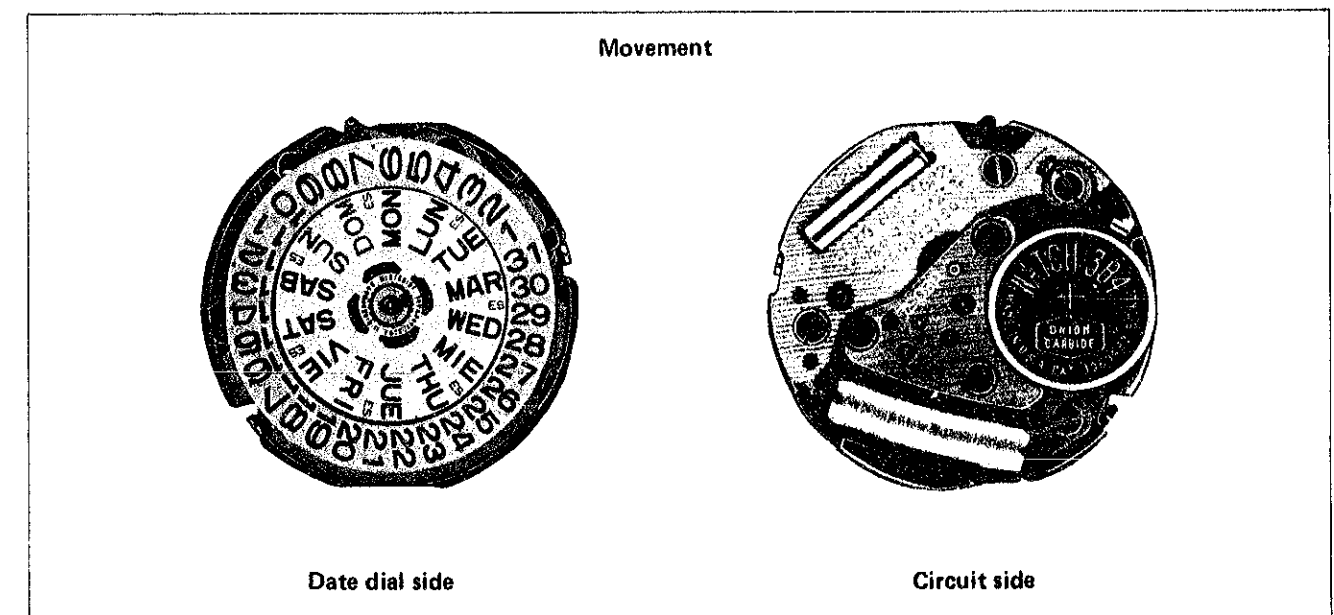





II. DISASSEMBLING, REASSEMBLING AND LUBRICATING

• Disassembling and reassembling

Disassembling procedures Figs.: ① → ④⑤

Reassembling procedures Figs.: ④⑤ → ①

• Lubricating





Types of oil	Oil quantity
 Moebius A	 Liberal quantity
 SEIKO watch oil S-6	 Normal quantity
Never lubricate the portions marked ⊗	 Extremely small quantity

• Movement holder

Use the movement holder S-648 when disassembling and reassembling.

List of screw used

The four types of screws used in Cal. 79 series are listed below.

Shape	Parts No.	Name	Shape	Parts No.	Name
	022 282	Minute wheel bridge screw (1 pc.) Date dial guard screw (3 pcs.)		022 468	Setting lever spring screw (1 pc.)
	022 424	Center wheel bridge screw (1 pc.) Third wheel bridge screw (3 pcs.) Circuit block screw (2 pcs.) Coil block screw (1 pc.) Second setting lever screw (1 pc.)		022 764	Dial screw (2 pcs.)

1. Disassembling, reassembling and lubricating of the calendar mechanism

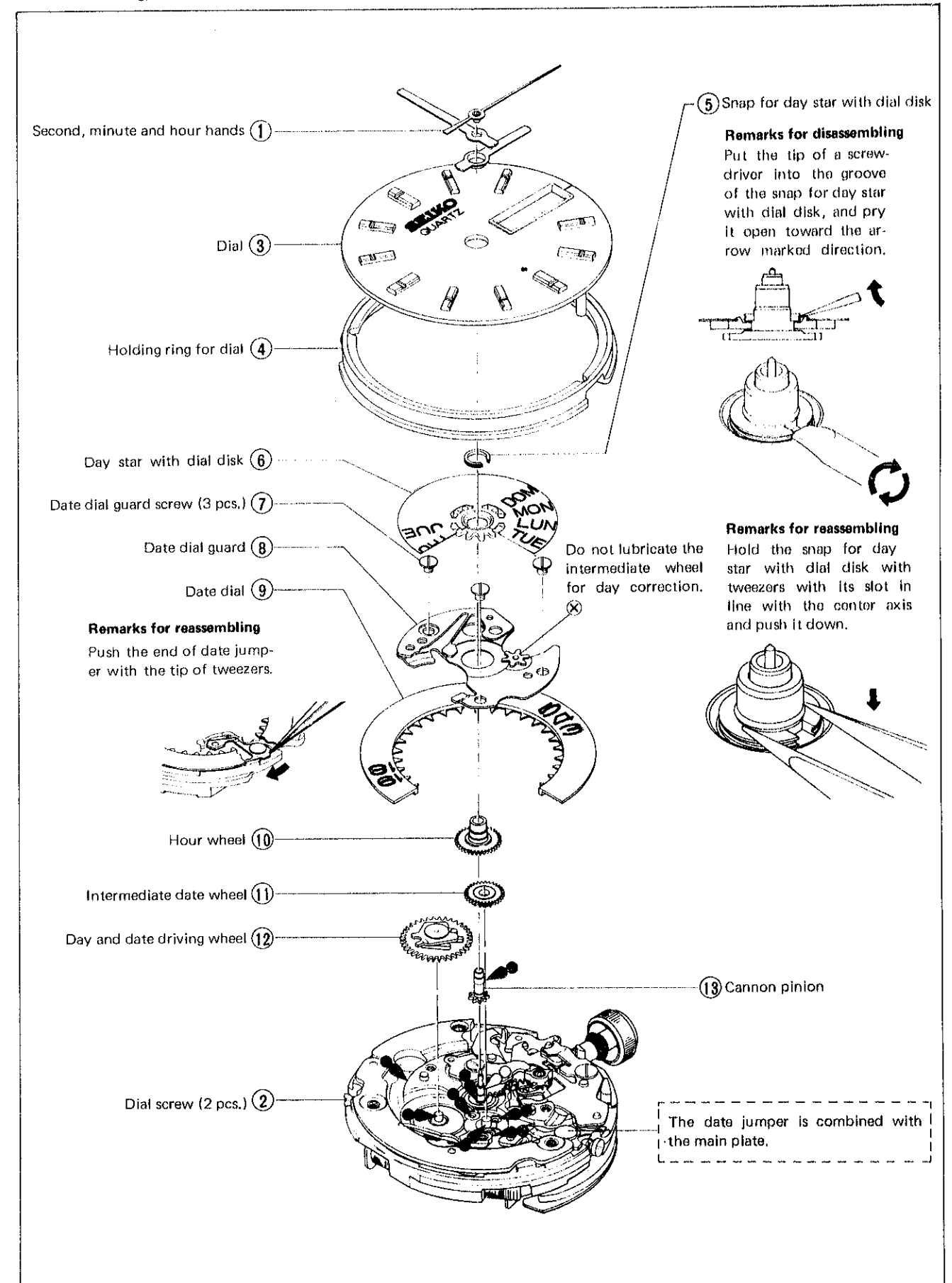

2. Disassembling, reassembling and lubricating of the circuit block, coil block and gear train mechanism

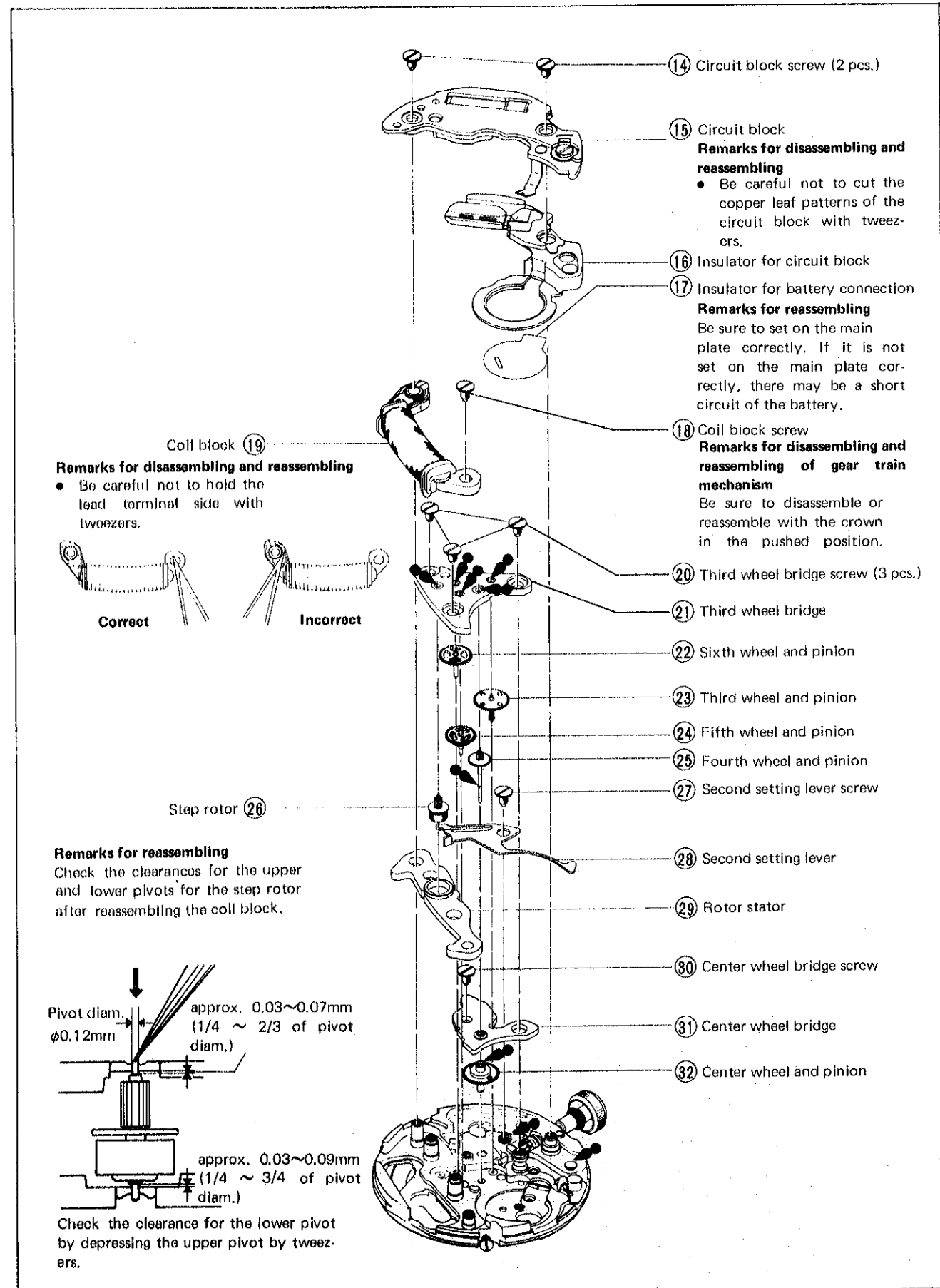

3. Disassembling, reassembling and lubricating of the setting mechanism

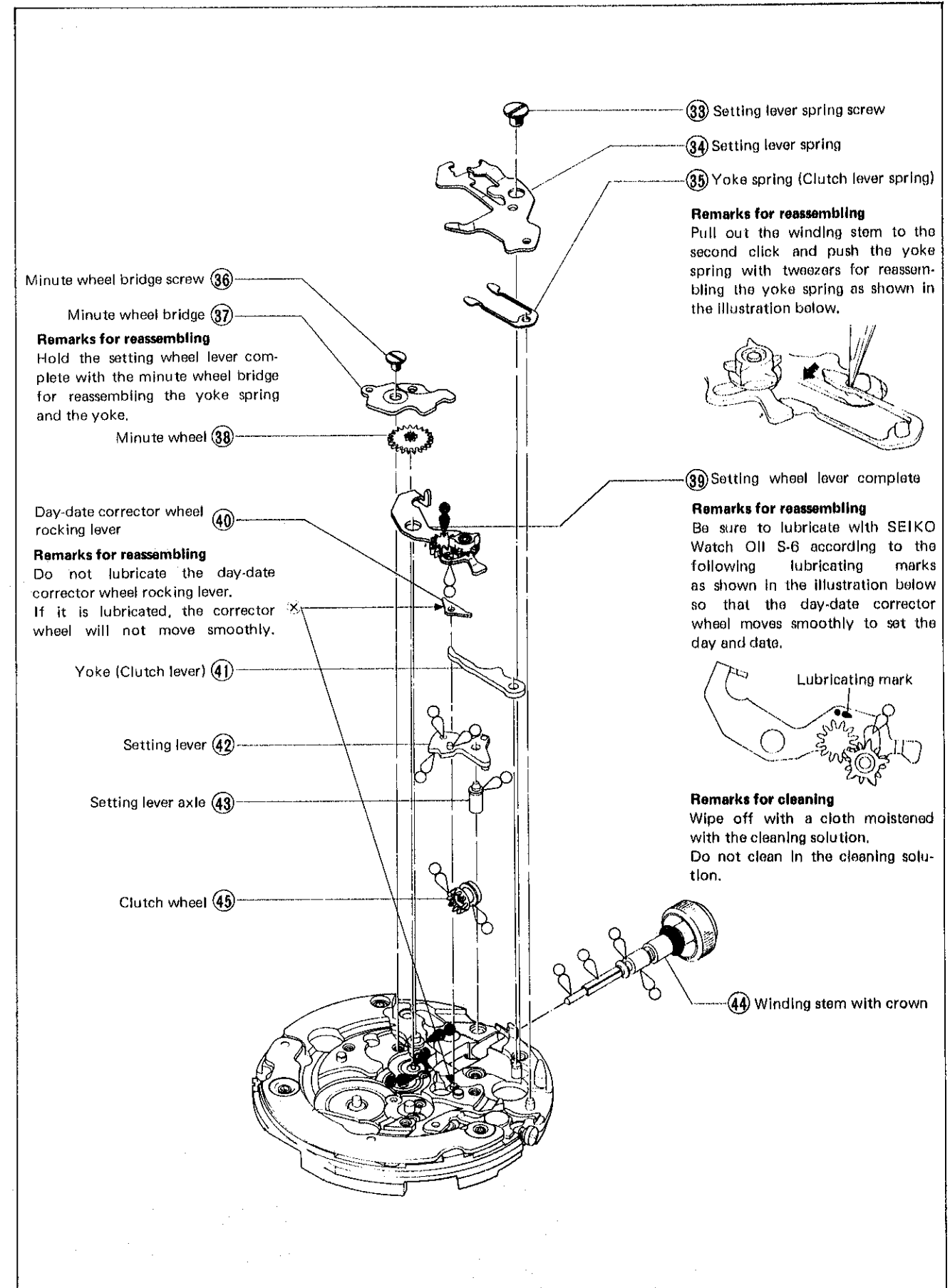

III. CHECKING AND ADJUSTMENT

1. Guide table for checking and adjustment

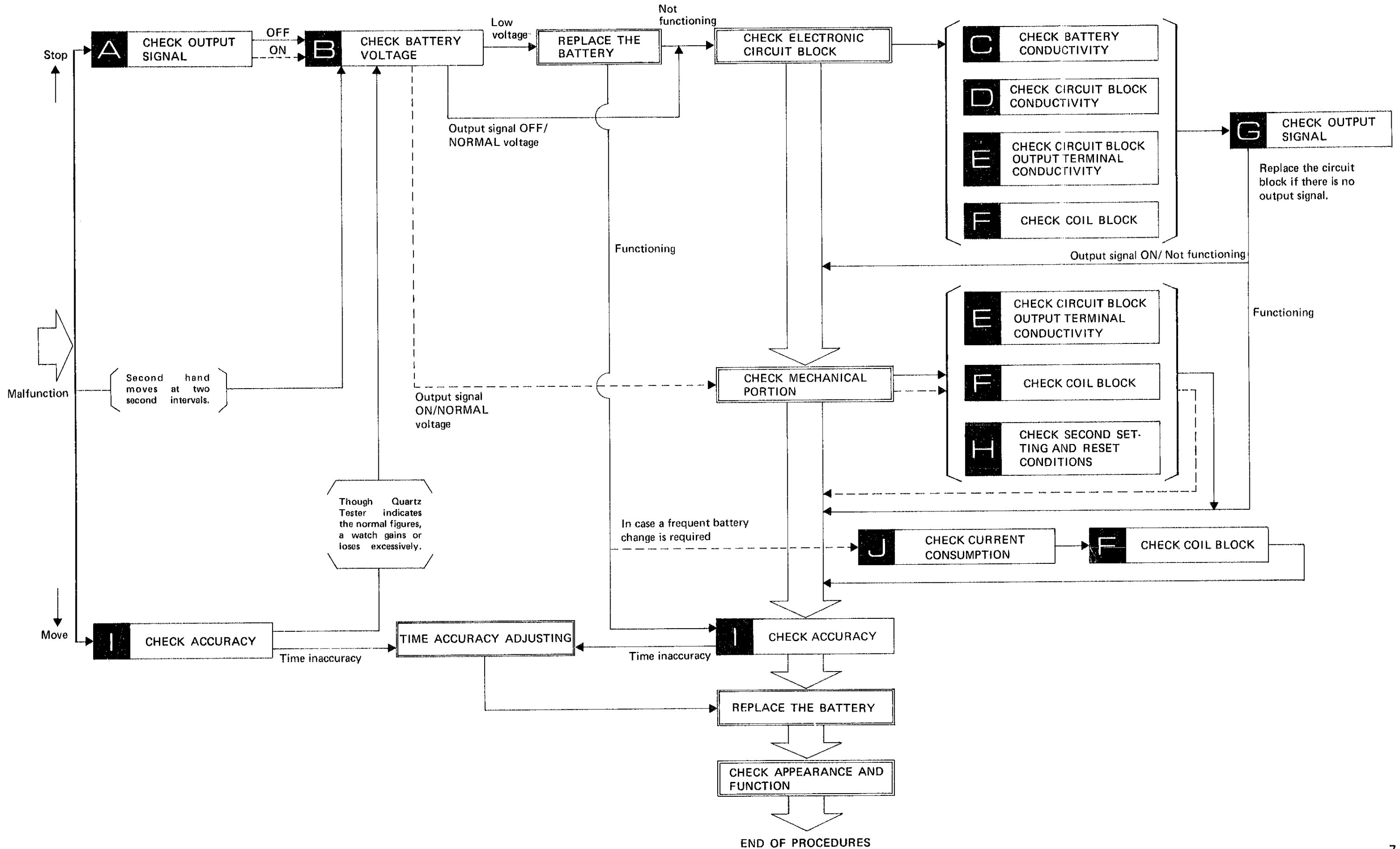

2. Procedures for checking and adjustment

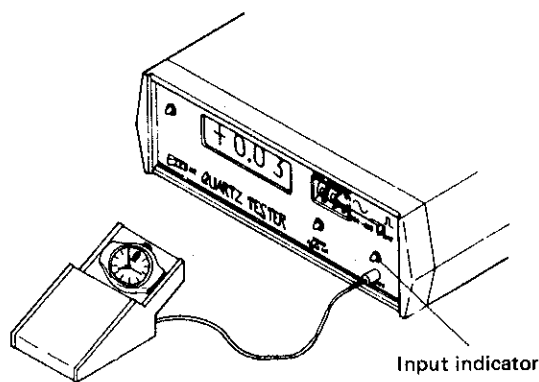
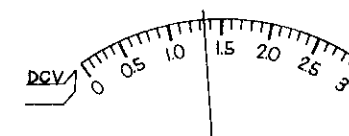
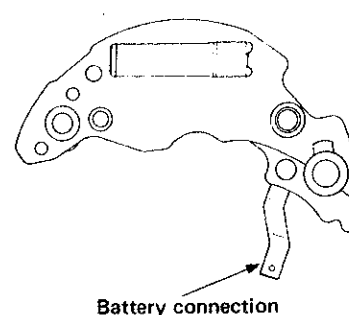
	Procedures	Result	Adjustment and Repair
CHECK OUTPUT SIGNAL	<p>Check for output signal.</p> <ol style="list-style-type: none"> 1. Set up the Quartz Tester. 2. Checking Check for blinking input indication lamp.  <p>Note: Push in the crown to the normal position.</p>	<p>One-second blinking — Normal</p> <p>No one-second blinking — Defective</p>	<p>Proceed to B.</p>
CHECK BATTERY VOLTAGE	<p>Check battery voltage.</p> <p>Note: When handling the battery, use non-metallic tweezers or fingercot.</p> <div style="border: 1px solid black; padding: 5px; margin-top: 10px;"> <p>When there is battery electrolyte leakage, refer to "HOW TO CHECK BATTERY ELECTROLYTE LEAKAGE AND REPAIR" below for repairing.</p> </div>	<p>More than 1.5V — Normal</p> <p>Less than 1.5V — Defective</p> 	<p>Proceed to Check mechanical portion if one-second blinking is found.</p> <p>Proceed to Check electronic circuit block if one-second blinking is not found.</p> <p>Replace the circuit block if the second hand moves at 2 second intervals.</p> <p>Proceed to Replace the battery.</p> <ul style="list-style-type: none"> • If the watch operates after battery replacement, proceed to I. • If the watch does not operate, proceed to Check electronic circuit block.
HOW TO CHECK BATTERY ELECTROLYTE LEAKAGE AND REPAIR	<ol style="list-style-type: none"> 1. Remove the movement from the case. 2. Disassemble the movement. 3. Wipe off battery electrolyte on the circuit block. <p>(1) Wipe off battery electrolyte with a cloth moistened with distilled water. (If distilled water is not available, use tap water.)</p> <p>Note: Do not expose the trimmer condenser to water or alcohol. If it is exposed, there may be a change in its condenser capacity and eventually in the time accuracy.</p> <ul style="list-style-type: none"> • Replace the part with a new one if the part is rusted to the extent that it is impossible to use. 	<p>Be sure to wipe off battery electrolyte on the battery connection.</p>  <p>Battery connection</p>	<ol style="list-style-type: none"> (2) Wipe them with a cloth moistened with alcohol. (If the cleaned portions remain wet with water, they will corrode with rust.) (3) Dry with hot air by using a dryer. 4. Wipe off battery electrolyte on the other parts. (Rinse the insulator for battery connection with water.) 5. Reassemble the movement. (Replace the battery with a new one.) 6. Check to see if the time setting functions and the current consumption are normal.

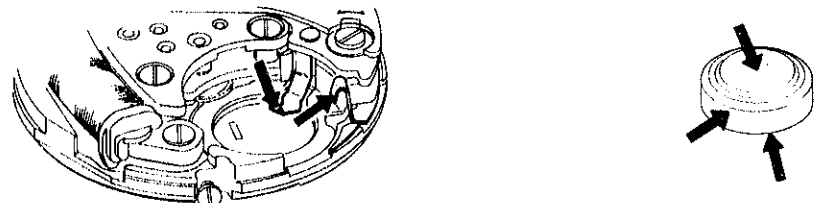
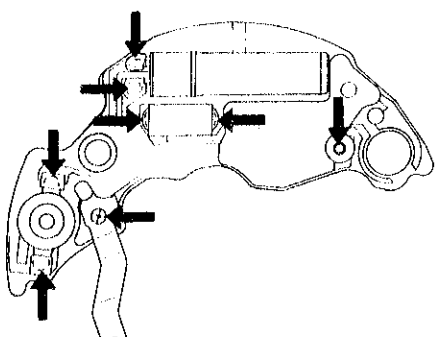
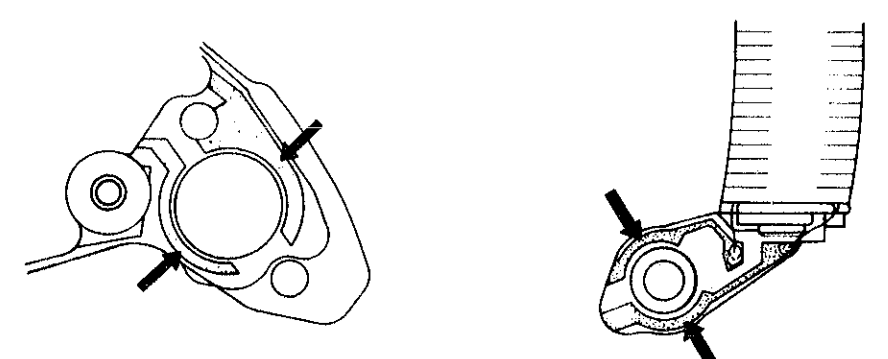
	Procedures	Result	Adjustment and Repair
C CHECK BATTERY CONDUCTIVITY	<p>Check to see if the battery current flow to the circuit is normal.</p> <p>Check for any stain on the connecting portions of the battery, the plus terminal of battery connection and the battery connection.</p> 	<p>Uncontaminated ————— Normal —————></p> <p>Contaminated ————— Defective —————></p>	<p>Proceed to D.</p> <p>Wipe off any foreign matter.</p> <p>Note: Be careful not to bend the plus terminal of battery connection and the battery connection.</p>
D CHECK CIRCUIT BLOCK CONDUCTIVITY	<p>Check for defective conductivity of the conductive portions of the circuit block.</p> <p>Disassemble the circuit block and check conductivity of the arrow-marked portions by using a microscope.</p> 	<p>No defective conductivity ————— Normal —————></p> <p>Defective conductivity ————— Defective —————></p>	<p>Proceed to E.</p> <p>Replace the circuit block with a new one.</p>
F CHECK CIRCUIT BLOCK OUTPUT TERMINAL CONDUCTIVITY	<p>Disassemble the circuit block and check the connecting portions of the circuit block output terminal and the coil block.</p> <p>Check for any foreign matter on the circuit block output terminal and the coil lead terminal.</p> 	<p>Uncontaminated ————— Normal —————></p> <p>Contaminated ————— Defective —————></p>	<p>Proceed to F.</p> <p>Wipe off the contamination.</p>

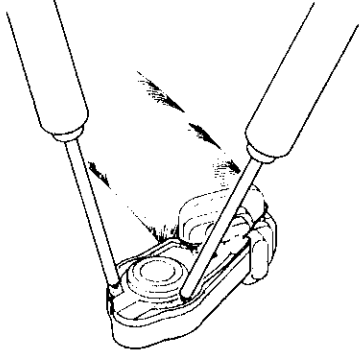
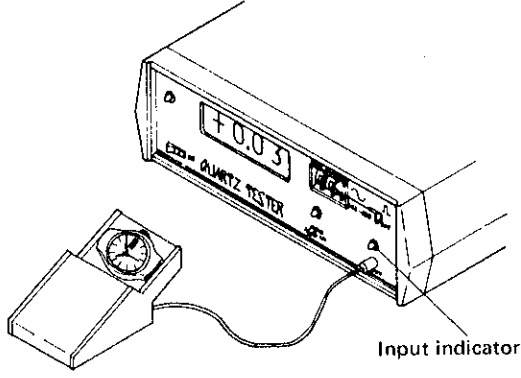
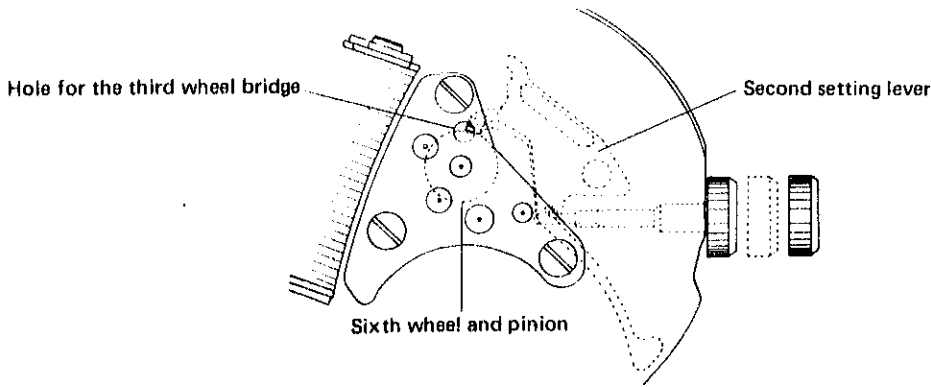
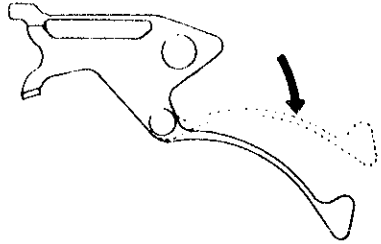
	Procedures	Result	Adjustment and Repair
II CHECK COIL BLOCK	<p>Check for broken coil wire and short circuit of the coil block.</p> <ol style="list-style-type: none"> 1. Set up the Volt-ohm-meter. Range to be used: OHMS R x 100 2. Checking Apply the red and black probes of the Volt-ohm-meter to the two coil lead terminals. 	<p>Pointer of the Volt-ohm-meter swings — Normal —></p> <p>Broken coil wire (Pointer of the Volt-ohm-meter hardly swings) — Defective —></p> <p>Short circuit (Pointer of the Volt-ohm-meter swings excessively) — Defective —></p>	<p>Proceed to G if the Electronic circuit block must be checked.</p> <p>Proceed to H if the Mechanical portion must be checked.</p> <p>Replace the coil block with a new one.</p>
G CHECK OUTPUT SIGNAL	<p>Check for output signal.</p> <ol style="list-style-type: none"> 1. Set up the Quartz Tester. 2. Checking <p>Follow the same procedures as in A</p> 	<p>One-second blinking — Functioning —></p> <p>One-second blinking — Not functioning —></p> <p>No one-second blinking — Defective —></p>	<p>Proceed to I.</p> <p>Proceed to Check mechanical portion H.</p> <p>Replace the circuit block with a new one.</p>
I CHECK SECOND SETTING CONDITION AND RESET CONDITION	<p>Check to see if the second setting condition and the reset condition are normal.</p> <ol style="list-style-type: none"> 1. Check to see if there is clearance between the second setting lever and the sixth wheel and pinion when the crown is in the normal and the first click positions. Also, check to see if the second setting lever touches the sixth wheel and pinion when the crown is in the second click position. (Check through the hole for the third wheel bridge by using a microscope.) 	<p>Functions — Normal —></p> <p>Does not function — Defective —></p>	<p>Proceed to H 2.</p> <p>Correct the bend of the second setting lever if there is any.</p>  <p>(If it is impossible to correct, replace the second setting lever with a new one.)</p>

Procedures

2. Check the reset condition after the circuit block and the battery are reassembled.
- (1) Check to see if the second hand stops immediately when the crown is pulled out completely and if it starts promptly one second after the crown is pushed in to the normal position.
 - (2) Check to see if the conductivity between the reset pin and the main plate is normal when the crown is pulled out completely.

- 1 Set up the Volt-ohm-meter.
Range to be used: OHMS R x 1

Note: Be careful not to use the range other than R x 1. The circuit might be damaged if another range is used.

- 2 Checking
Apply one of the probes of the Volt-ohm-meter to the third wheel bridge and the other probe to the reset pin.

Either red or black probe will do.

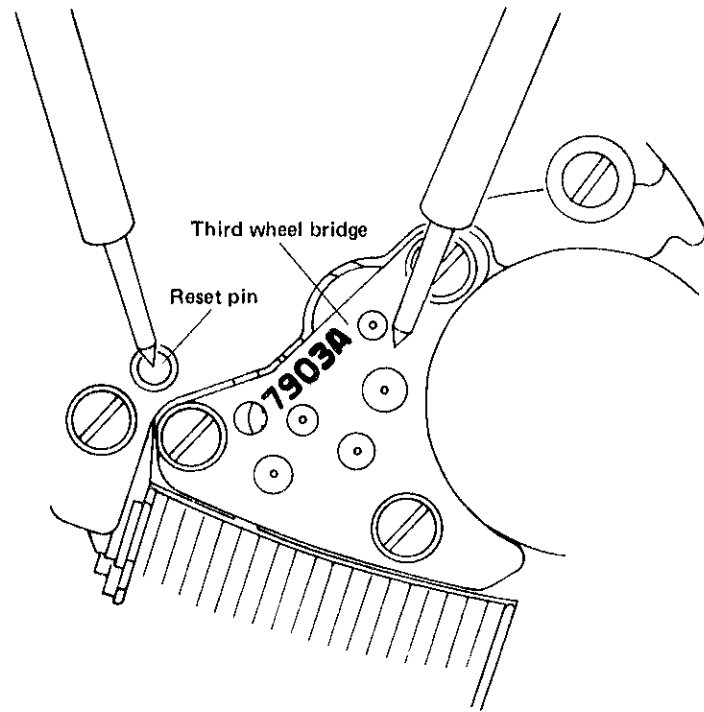

Result

Stops completely and starts moving after one second — Normal —>

Does not stop or moves irregularly — Defective —>

Less than 10Ω — Normal —>

More than 10Ω — Defective —>

Adjustment and Repair

Proceed to



Proceed to



Replace the circuit block with a new one.

Make the repairs below as the contact between the reset pin and the second setting lever is defective.

1. Check for the bend of the second setting lever and the reset pin and correct if any.

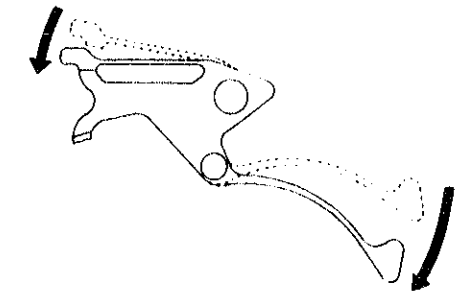

2. Check for dust, lint or other contamination on the connecting portions of the reset pin and the second setting lever.
Wipe off any foreign matter.

Check gain and loss of time.

1. Set up the Quartz Tester.
2. Checking
Check by using the same procedure as in

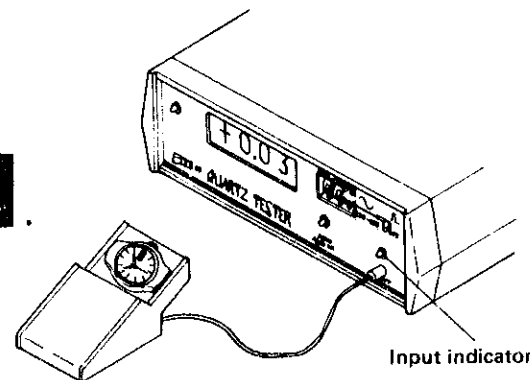

Normal —>

Defective —>

Follow the procedures shown on page 7.

Proceed to

Time accuracy adjusting

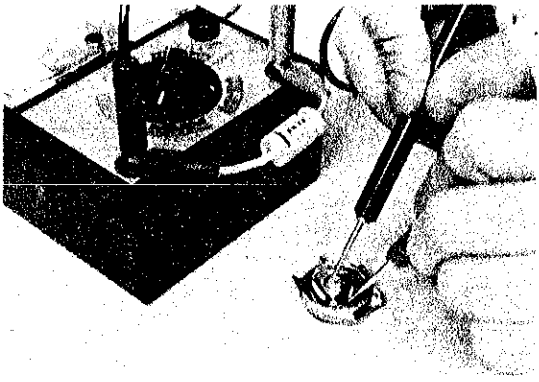
CHECK CURRENT CONSUMPTION	Procedures
	<p>In case where a frequent battery change is required, a current consumption test is recommended.</p> <ul style="list-style-type: none"> Probe Red (+) Battery connection Probe Black (-) Battery surface (-) <div style="text-align: center;">  </div> <p>Note: Be sure to measure with the crown of the watch in the pushed-in position.</p>

Result	Adjustment and Repair
Less than $2.5\mu A$ →	Proceed to I .
More than $2.5\mu A$ →	Proceed to F . When the coil block functions normally, replace the circuit block with a new one.
All procedures of Disassembling, Reassembling, Checking and Adjustment are completed.	