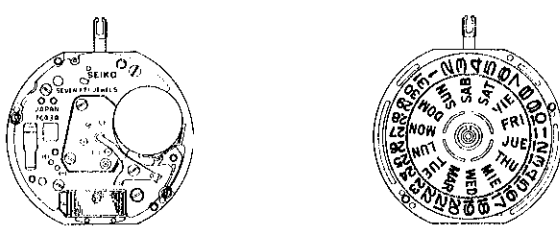

PARTS CATALOGUE/ TECHNICAL GUIDE

Cal. 7C43A Cal. 7C46A

[SPECIFICATIONS]

Cal. No.		7C43A	7C46A
Item			
Movement		 <p>The illustrations refer to Cal. 7C43A. (x 1.0)</p>	
Movement size	Outside diameter	$\phi 26.0$ mm 24.0 mm between 3 o'clock and 9 o'clock sides	$\phi 28.6$ mm 27.0 mm between 3 o'clock and 9 o'clock sides
	Casing diameter	$\phi 24.0$ mm 24.0 mm between 3 o'clock and 9 o'clock sides	$\phi 27.0$ mm 25.4 mm between 3 o'clock and 9 o'clock sides
	Height	3.7 mm without battery	
Time indication		3 hands	
Driving system		Step motor (Load compensated driving pulse type)	
Additional mechanism		<ul style="list-style-type: none"> • Train wheel setting device • Day and date calendar • Instant calendar setting device • Electronic circuit reset switch • Battery life indicator 	
Loss/gain		Monthly rate at normal temperature range: less than 15 seconds	
Regulation system		Pattern cutting system	
Measuring gate by quartz tester		Use 10-second gate.	
Battery		SEIKO TR927SW, Maxell SR927SW, U.C.C. 395, SONY EVEREADY 395 Battery life is approximately 3 years. Voltage: 1.55V	SEIKO SR43SW, Maxell SR43SW, U.C.C. 301, SONY EVEREADY 301 Battery life is approximately 5 years. Voltage: 1.55V
Jewels		7 jewels	

PARTS CATALOGUE

1. Setting mechanism (Cal. 7C43A, 7C46A)

Cal. 7C43A, 7C46A

Disassembling procedures Figs.: ①' → ①6'

Reassembling procedures Figs.: ①6' → ①'

Lubricating: Types of oil



- Moebius A
- ⊖ Moebius F
- SEIKO Watch Oil S-6



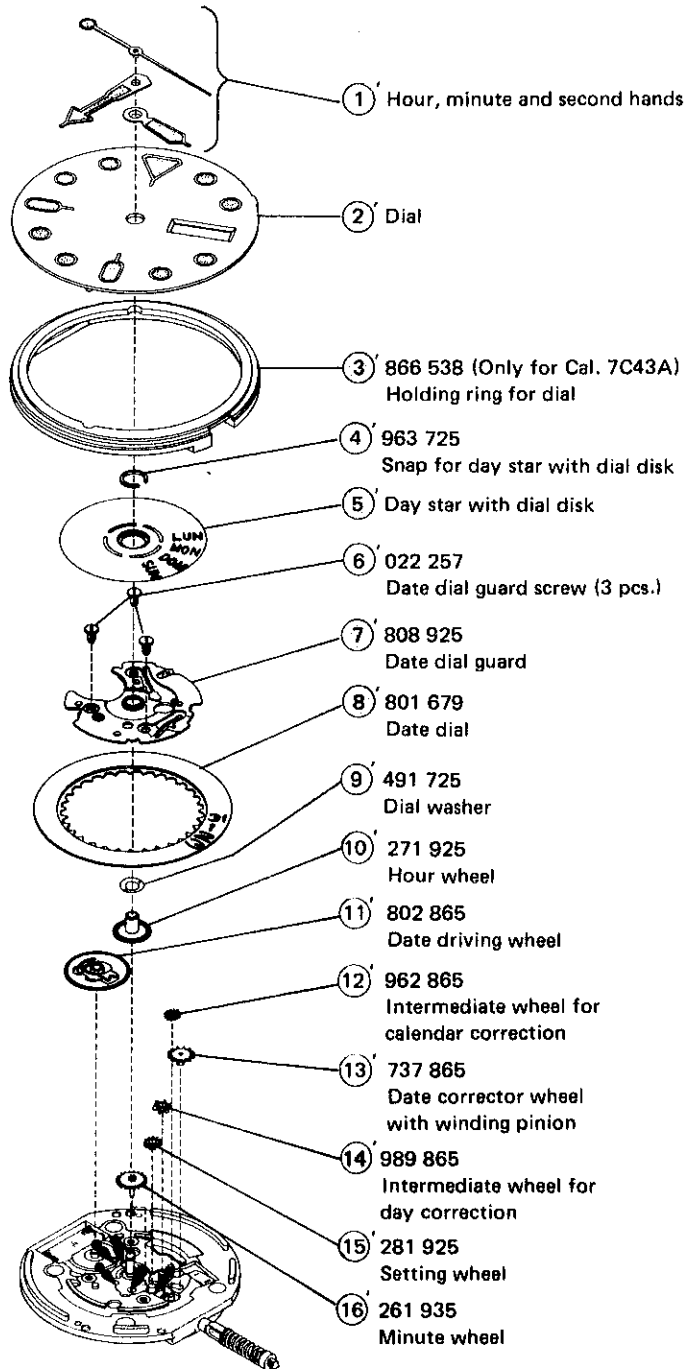



Oil quantity

- Normal quantity



○ ⇨ Please see the remarks on the following pages.

022 257 	Date dial guard screw
022 493 	Antimagnetic shield plate screw Train wheel bridge screw Friction spring screw Battery connection (+) screw (Cal. 7C43A) Coil block screw (Cal. 7C46A)
022 648 	Battery clamp screw (Cal. 7C46A)

027 219 	Tube for train wheel bridge
027 220 	Tube for circuit block screw A
027 221 	Tube for circuit block screw B
027 222 	Tube for antimagnetic shield plate screw
027 223 	Tube for battery connection (+) screw (Cal. 7C43A) Tube for coil block screw (Cal. 7C46A)
027 308 	Setting lever pin
027 972 	Eccentric dial pin

PARTS CATALOGUE

2. Gear train mechanism (Cal. 7C43A)

Cal. 7C43A

Disassembling procedures Figs.: ① → ③①
 Reassembling procedures Figs.: ③① → ①

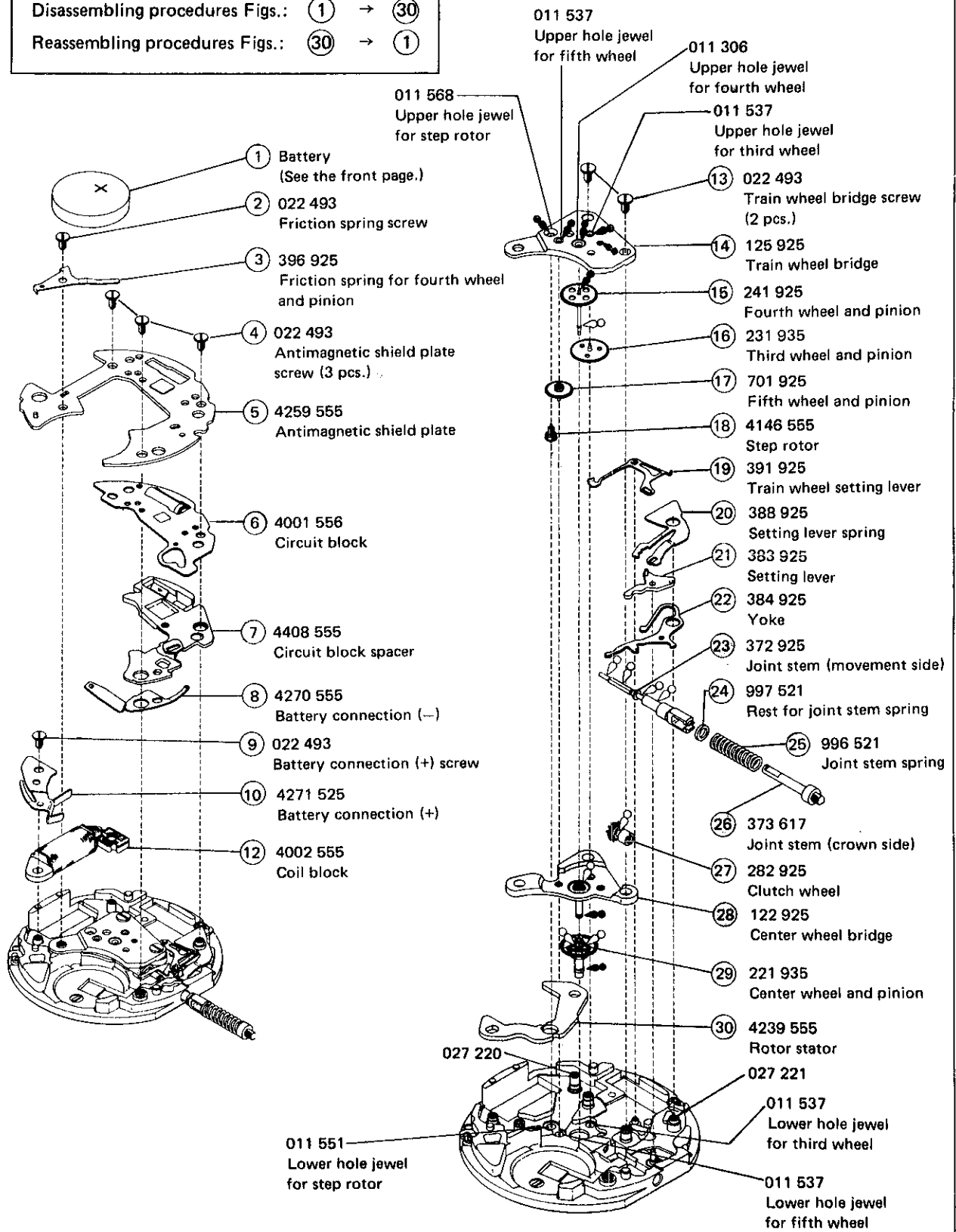

○ ⇨ Please see the remarks on the following pages.

PARTS CATALOGUE

3. Gear train mechanism (Cal. 7C46A)

Cal. 7C46A

Disassembling procedures Figs.: ① → ③①

Reassembling procedures Figs.: ③① → ①

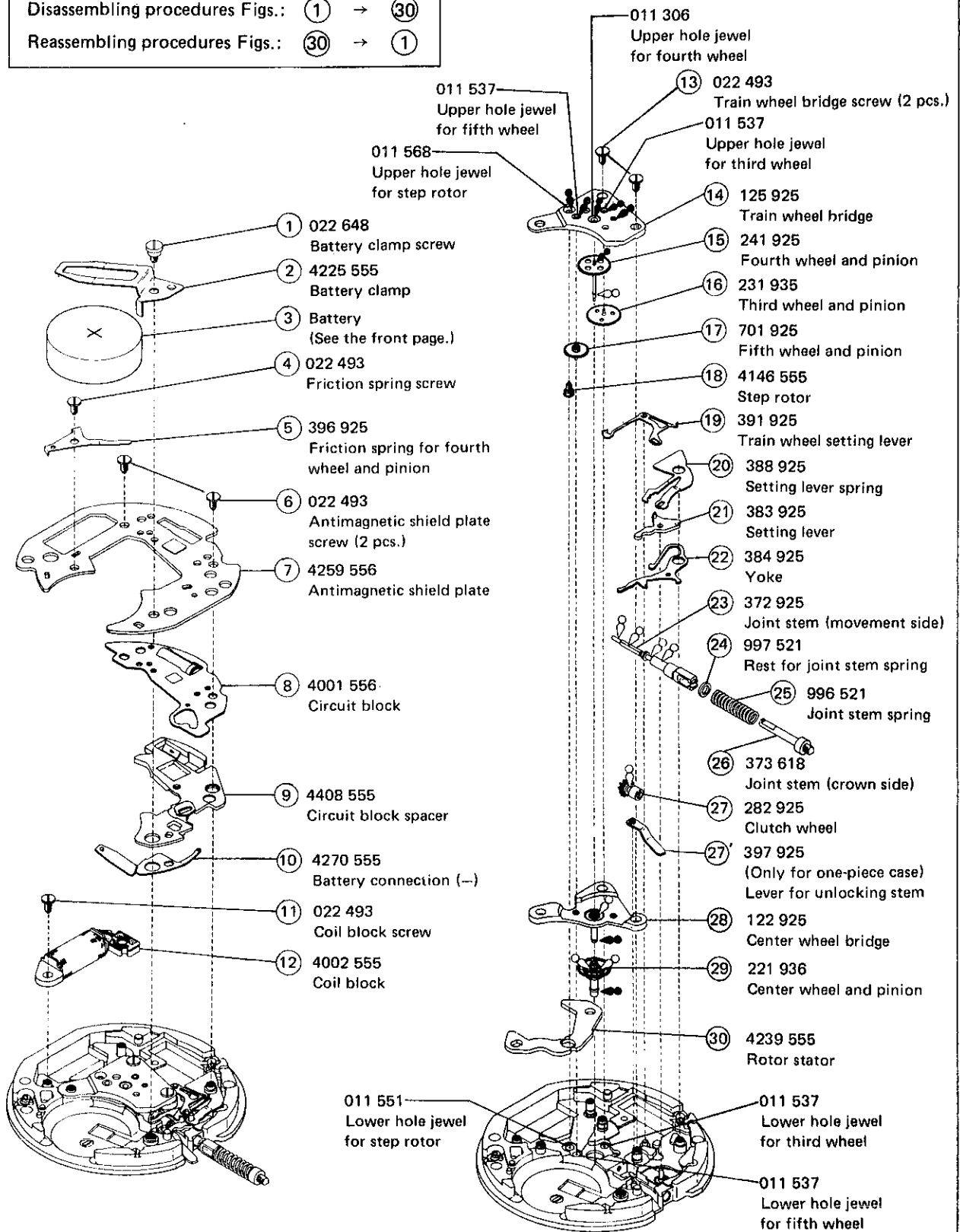

○ ⇨ Please see the remarks on the following pages.

PARTS CATALOGUE

Cal. 7C43A, 7C46A

Remarks:

- ③ Holding ring for dial (Only for Cal. 7C43A) 866 538
- ②③ Joint stem (movement side) 372 925
- ②⑥ Joint stem (crown side) 373 617 (Cal. 7C43A), 373 618 (Cal. 7C46A)

The types of these parts are determined based on the design of each model.
Refer to "SEIKO Casing Parts Catalogue" to choose corresponding parts.

⑤ Day star with dial disk

Part code	Position of crown	Position of calendar	Language	Color of figure	Color of background
470 755	4 o'clock	3 o'clock	English ↔ Japanese	Black	White
470 877	4 o'clock	3 o'clock	English ↔ Spanish	Black	White

If any other type of day star with dial disk is required, please specify the number inscribed on the disk.

⑧ Date dial

Part code	Position of crown	Position of calendar	Color of figure	Color of background
801 679	4 o'clock	3 o'clock	Black	White

If any other type of date dial is required, please specify ① Cal. No., ② the crown position, ③ the calendar frame position, and ④ Dial No.

- The explanation here is only for the particular points of Cal. 7C43A and 7C46A.
- For the repairing, checking and measuring procedures, refer to the "TECHNICAL GUIDE, GENERAL INSTRUCTION".

I. STRUCTURE OF THE CIRCUIT BLOCK

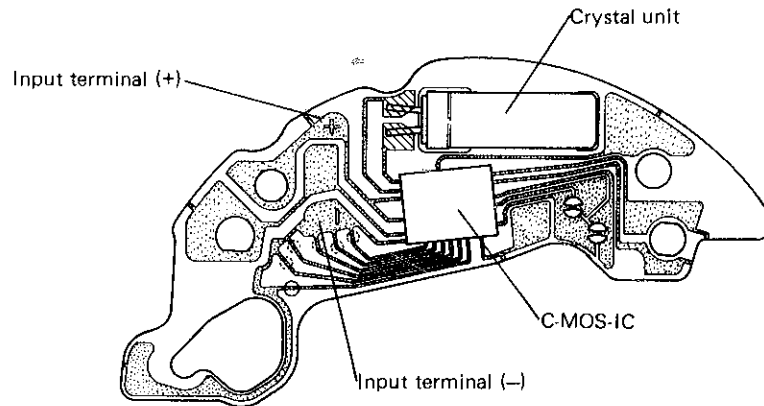

II. REMARKS ON DISASSEMBLING AND REASSEMBLING

Use the universal movement holder for disassembling and reassembling.

② Dial

- **How to remove**

The dial legs (2 places) are tightened by the eccentric dial pins. Loosen the eccentric dial pins with a screwdriver to remove the dial.

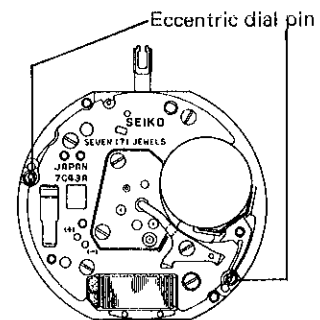

⑦ Date dial guard

- **Setting position and lubricating**

The date dial guard is fixed by two guide pins of the main plate. Press the date dial guard after setting its date jumper portion in position to engage the cogs of the date dial.

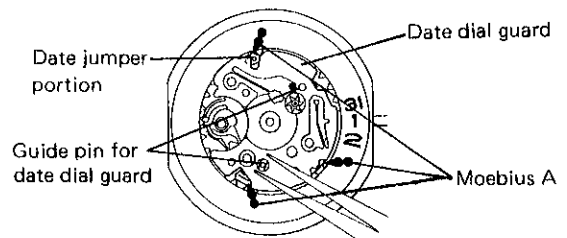

⑭ Intermediate wheel for day correction

- **Remarks on installing**

Install the intermediate wheel for day correction with its flat side up.

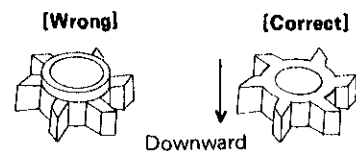

⑮ Fourth wheel and pinion

- **Lubricating**

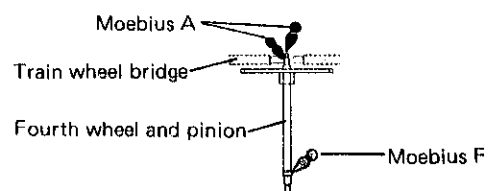

①9 Train wheel setting lever

• Setting position and lubricating

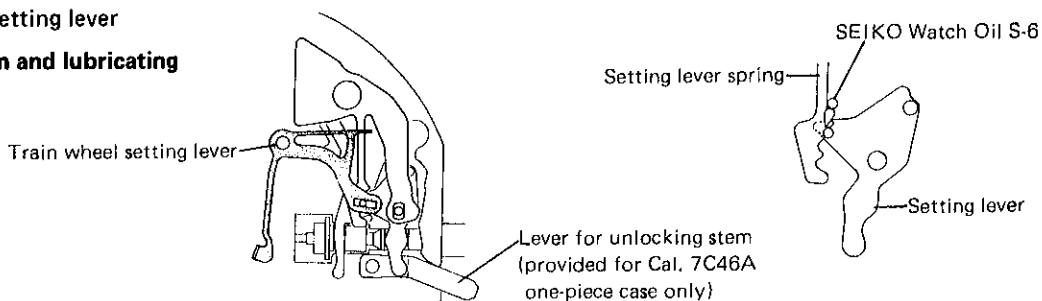

②8 Center wheel bridge

• Lubricating

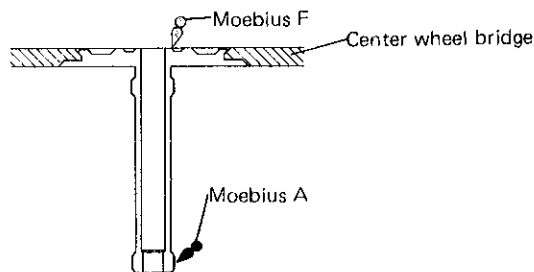

III. VALUE CHECKING

• Coil block resistance

2.1KΩ ~ 2.5KΩ

• Current consumption

For the whole of the movement: less than 1.5μA

For the circuit block alone: less than 0.3μA

Remarks:

When the current consumption exceeds the standard value for the whole of the movement but is less than the standard value for the circuit block alone, overhaul and clean the movement parts and then measure current consumption for the whole of the movement again. The driving pulse generated to compensate a heavy load that may apply on the gear train, etc. is considered to cause excessive current consumption for the whole of the movement.

• Time accuracy adjusting

1. Confirm the appropriate pattern to be cut over the antimagnetic shield plate.

(-) pattern : to lose approximately 0.26 sec./day

(+) pattern : to gain approximately 0.26 sec./day

2. Take off the antimagnetic shield plate.
3. Cut the pattern on the circuit block.
4. Remove the sludge completely.

Ex.: The illustration below shows that the (+) pattern is cut to gain time.

